

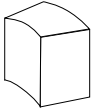

Integrated Solid



Nugget Cube:



### Additional Options

- Stainless steel panel accessory



### Key Features

- **No water filtration required**
- **Produces up to 65 lb of ice per day**
- Bright white LED lighting
- Built-in or freestanding
- Concealed soft close articulating hinge
- Digital touch pad control
- Easy 20 minute clean cycle
- Factory installed drain pump
- Field reversible door is shipped right-hand hinged
- Four adjustable leveling legs
- Indicator alert notifies user if water issues are detected
- Makes compressed ice bits approx. 1/2"L x 3/8"H x 5/8"W
- Requires 3/4" custom door panel and handle (not supplied by U-Line) or stainless panel accessory
- Stores 27 lb of ice
- UV light activated when door is closed
- White interior

### Model Details

Model	Voltage/Hz	Door Swing	Pump	Finish	Shipping Weight
URNP115-IS01A	115 / 60	Field Reversible	Pump Included	Integrated Solid	104 lb

### Accessories

Model	Description	Finish	Shipping Weight
ULA15SPNUGGETSOLID	Stainless Steel Door Panel with Tube Style Handle	Stainless	10 lb
80-55667-00	Ice Machine Cleaner (Single 4 oz. bottle)	N/A	1 lb
ULAWATERHOOKUP	Braided Water Supply Line Kit	N/A	2 lb
90-54206-08	Ice Machine Cleaning Bottle	N/A	1 lb

**Front**

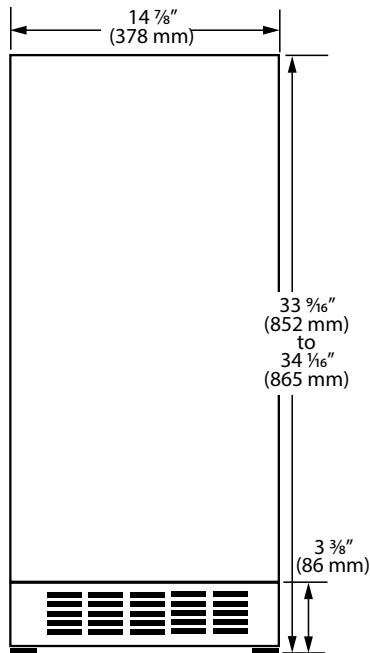

**Side**

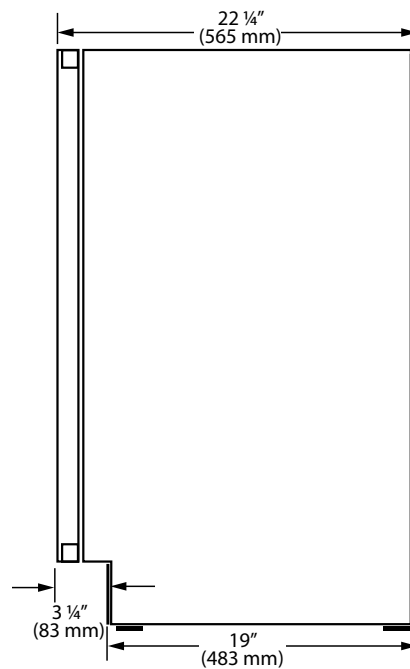

\*Add 1/2" for Integrated models with 3/4" integrated panel installed.

**Top**

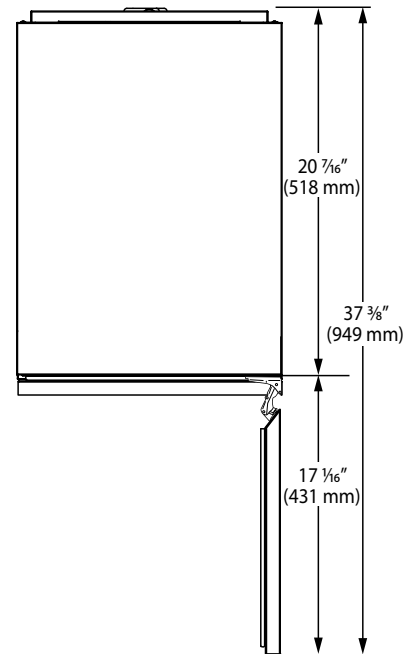

**Specifications**

Model	URNP115-IS01A
Amps: Running	3
Dimensions: Product Depth	22 1/4" / 565 mm
Dimensions: Product Height	33 9/16" / 852 mm
Dimensions: Product Width	14 7/8" / 378 mm
ENERGY STAR	Yes
Ice Production Per Day	65 lb
Ice Storage	27 lb
Panel Height	30" / 762mm
Panel Thickness	3/4" 20mm
Panel Type	Solid Panel
Panel Width	14 15/16" / 379 mm
Product Weight: Max	101 lb
Refrigerant Type:	R600a

**Back**

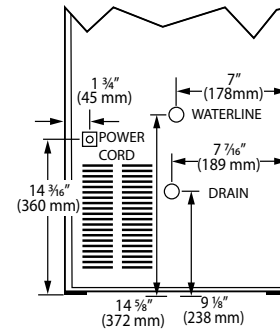

**Cabinet Cut-Out**

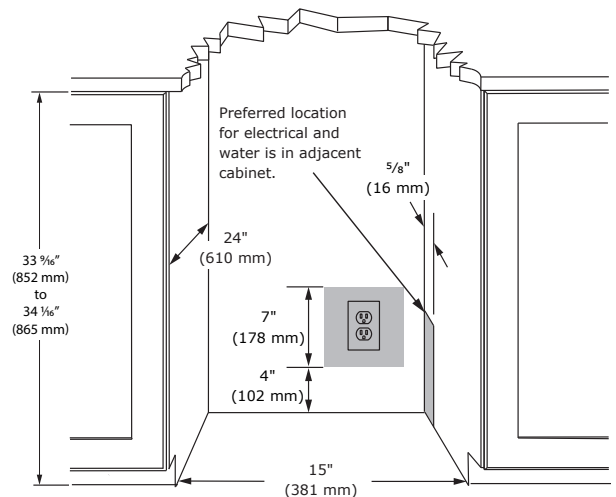

**Installation Notes**

- No additional clearance is needed for ventilation
- Do not obstruct front grille air flow

**Warranty**

Bonus Warranty through 2026 - 2 years (parts & labor) / 5 year (sealed system). See complete warranty for details.

