

CLIMATE

VARIABLE CAPACITY CHILLERS

The VARCX chiller automatically matches its capacity to the thermal load of your vessel. This maximizes the system's efficiency and reduces electrical load fluctuations on your generator, allowing you to both maximize your boat's electrical efficiency and maintain a constant temperature in the chiller system's water loop. The VARCX series is available in four different capacity ranges.

VARIABLE CAPACITY
OUTPUT MATCHES DEMAND

STEADY OPERATION
MAXIMUM EFFICIENCY

TITANIUM CONDENSER
IMPERVIOUS TO WEAR



208-230V/50/60Hz
380V/50Hz
460V/60Hz



48,000 - 120,000 BTU/h

Mobile living made easy.

 **DOMETIC**

MAXIMIZE EFFICIENCY & REDUCE LOAD FLUCTUATIONS

Maximize chiller efficiency and reduce electrical load fluctuations with the innovative Variable Capacity Chiller (VARCX) that modulates compressor speed to precisely match demand. Its robust titanium condenser, impervious to erosion and corrosion, extends the life of the unit. Its Electronic Expansion Valve provides more precise control of superheat.

Key Benefits

- Variable capacity increases or decreases output as the BTU load changes to maintain a constant temperature
- Harmonics are significantly reduced to promote a cleaner sine wave from the generator
- Ramp start avoids large inrush current
- Titanium condenser coil extends system life
- Operates steadily at lower speeds to provide maximum efficiency
- Electronic expansion valve provides precise control of superheat
- Eco Mode limits maximum power requirement
- Load shedding assists in power management
- Compact footprint saves space in engine room

Special Options

- Interactive high-resolution 7" / 178mm graphical touchscreen display provides a dynamic interface and improved system metrics and control
- VARCX can be manufactured to include up to 6 stages with manifolds and base



Model	VARCX48E	VARCX60	VARCX72			VARCX120		
Capacity (BTU)	12,000-48,000	15,000-60,000	18,000-72,000			30,000 - 120,000		
Voltage (V)	208-230	208-230	208-230	208-230	380-460	230	230	380-460
Cycle (Hz)	50/60	50/60	50/60	50/60	50/60	50/60	50/60	50/60
Phase (Ph)	1	1	1	3	3	1	3	3
Full Load Amps (FLA) Cool	14.6	24.6	27.2	15.9	9.9	46	20.1	16.0
Full Load Amps (FLA) Heat	17.5	18.9	25.8	15.7	12.6	37	28.3	21.5
Refrigerant	410A	410A	410A	410A	410A	410A	410A	410A
Seawater Connection OD Tube FPT (in/mm)	1.0 / 25	1.25 / 32	1.25 / 32	1.25 / 32	1.25 / 32	*(2x)1.25 / 32	*(2x)1.25 / 32	*(2x)1.25 / 32
Chilled Water Connection FPT (in/mm)	1.0 / 25	1.0 / 25	1.0 / 25	1.0 / 25	1.0 / 25	1.5 / 38	1.5 / 38	1.5 / 38
Drain Connection (in/mm)	0.5 / 13	0.5 / 13	0.5 / 13	0.5 / 13	0.5 / 13	0.5 / 13	0.5 / 13	0.5 / 13
Net Weight (lbs/kg)	108 / 49	172 / 78	190 / 86	190 / 86	190 / 86	315 / 143	315 / 143	315 / 143
Gross Weight (lbs/kg)	194 / 88	236 / 107	260 / 118	260 / 118	260 / 118	435 / 197	435 / 197	435 / 197
Height (in/mm)	19.7 / 501	24.0 / 610	24.0 / 610	24.0 / 610	24.0 / 610	30.4 / 772	30.4 / 772	30.4 / 772
Width (in/mm)	13.0 / 330	13.3 / 338	13.3 / 338	13.3 / 338	13.3 / 338	16.1in / 409	16.1in / 409	16.1in / 409
Depth (in/mm)	19.7 / 500	24.0 / 610	24.0 / 610	24.0 / 610	24.0 / 610	32.0 / 813	32.0 / 813	32.0 / 813
Height-Electrical Box (in/mm)	14.2 / 361	14.2 / 361	14.2 / 361	14.2 / 361	14.2 / 361	14.2 / 361	14.2 / 361	14.2 / 361
Width-Electrical Box (in/mm)	11.7 / 298	11.7 / 298	11.7 / 298	11.7 / 298	11.7 / 298	14.2 / 361	14.2 / 361	14.2 / 361
Depth-Electrical Box (in/mm)	4.1 / 105	4.1 / 105	4.1 / 105	4.1 / 105	4.1 / 105	4.1 / 106	4.1 / 106	4.1 / 106

* VARCX120 Seawater Connection has two inlets and two outlets at 1.25in/32mm.

Note: All FLA values are rated at standard conditions: Cooling at 85F (29.5C) seawater / Heating at 50F (10C) seawater. FLA values change with seawater temperatures

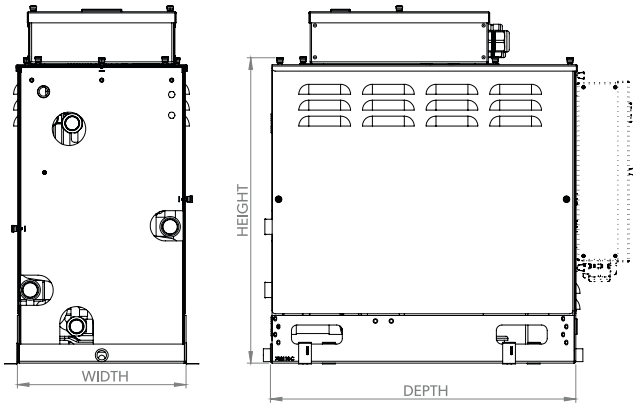

VARCX60/72

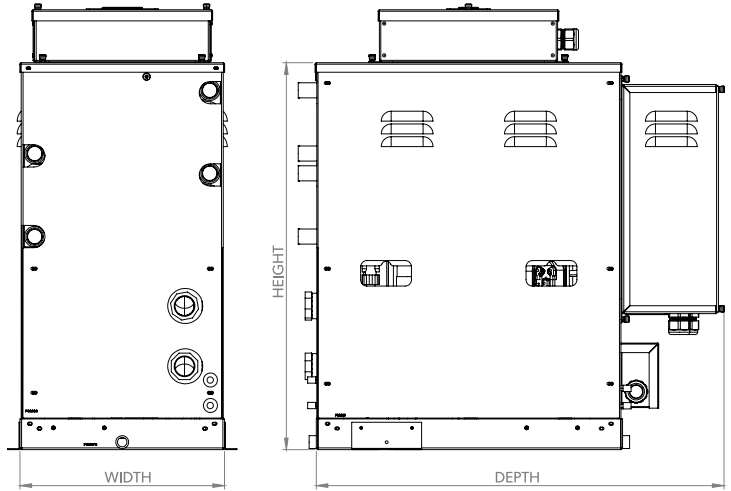

VARCX120

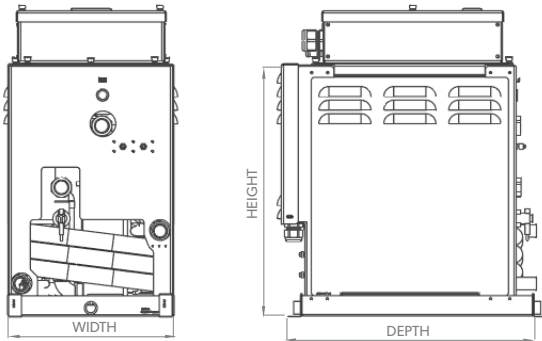

VARCX48E

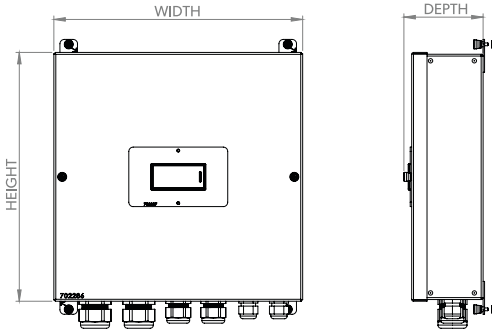

VARCX120 ELECTRICAL BOX

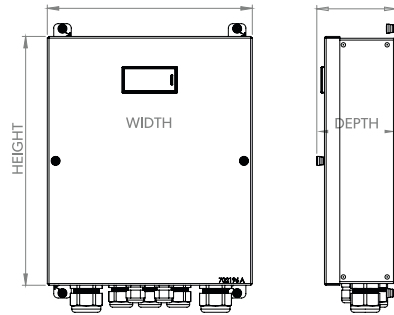

VARCX48, 60, 72 Electrical Box

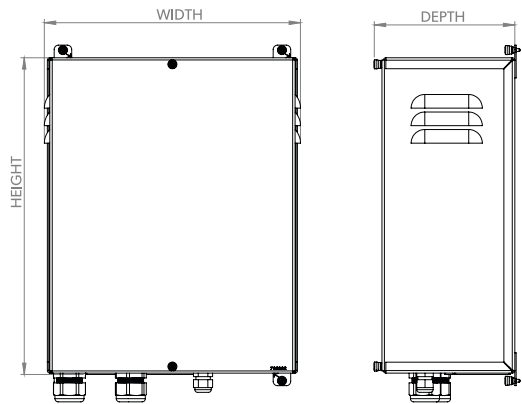

VARCX120 VFD ENCLOSURE

MAXIMIZE EFFICIENCY & REDUCE LOAD FLUCTUATIONS

Remote electrical box can be mounted on top or on back of unit, or on a bulkhead for easy access



1. Titanium Condenser Coil



2. Convenient Service Access



3. Digital Display



4. Integrated Handles

(not available on VARCX48)